

1

2

3

Autodesk

4

5

6

TANK

TANK CONTENTS	DIESEL
DESIGNED TO	AS1940,UL142,ULCS601
BUILT TO	AS1692,CAT.3,UL142,ULCS601
PLATE THICKNESS	5(Q235 Outer) / 5(Q235 Inter)mm
PRESSUE TEST	35KPA
GROSS VOLUME	30,900 L
SAFE FILL LEVEL	29,350 L
TOTAL MASS	6,600 KG

A

B

C

D

E

F

G

H

Autodesk

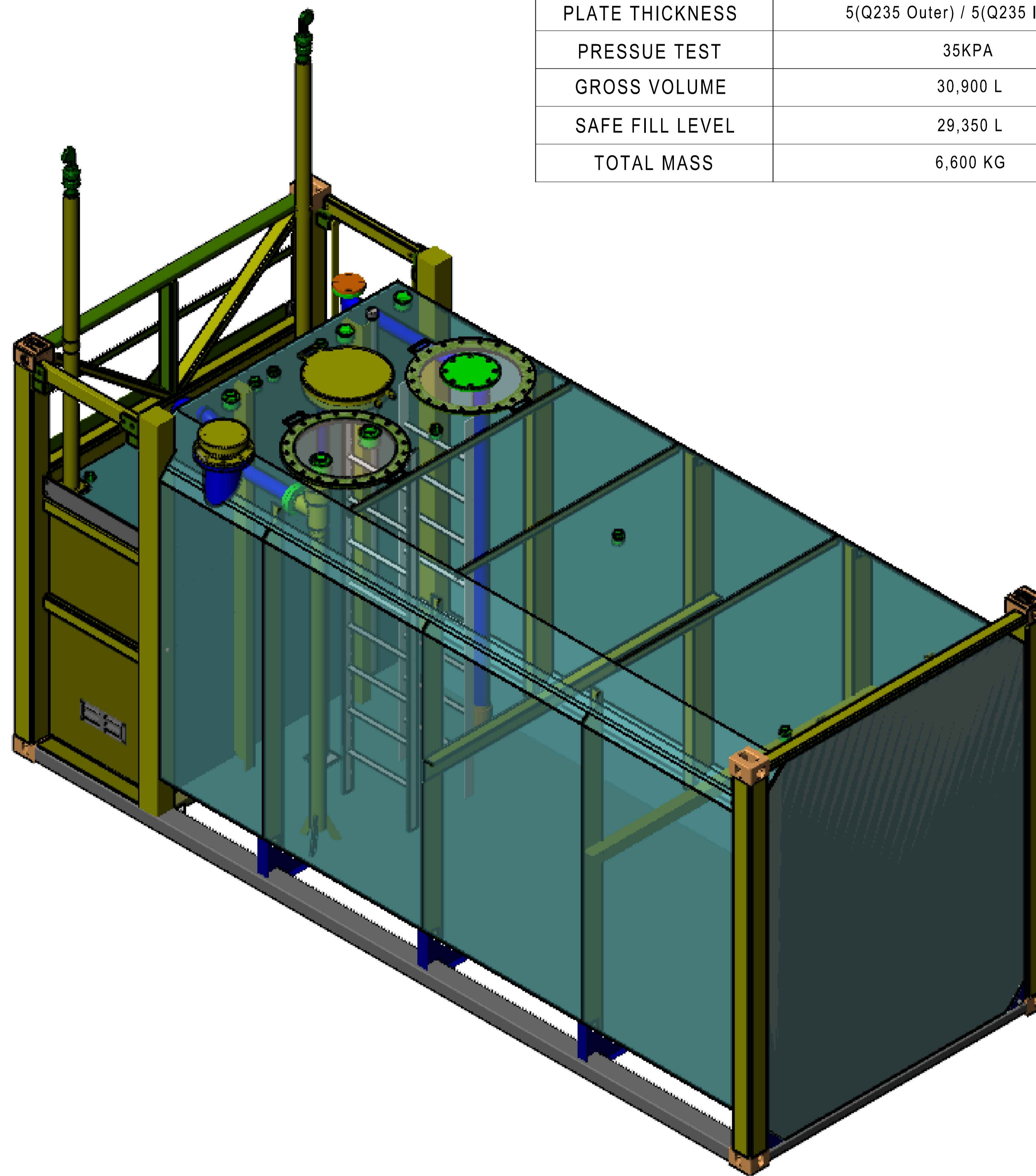
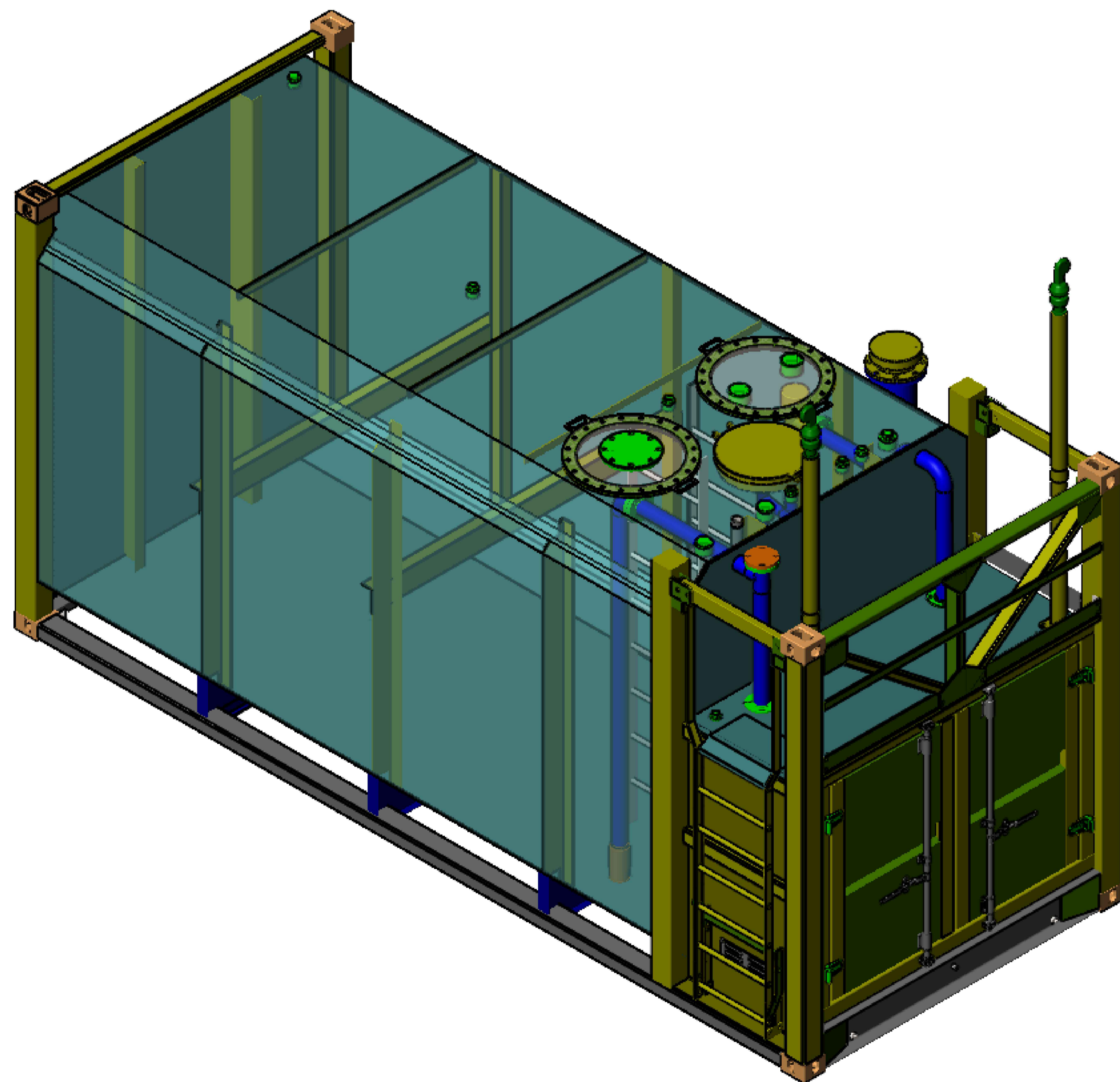

						Project :		
						Part Name : BT-30 LAYOUT		
				Material		Part No :		
				Weight		6600 KG		
				Revision		01 SHEET 1 TOTAL SHEET 3		
N0.	Changes File	SIGN	DATE					
Design	2024/9/12	Number						
CHK' D		Scale						
CHK' D								
APPV' D								

1

2

3

Autodesk

4

5

6

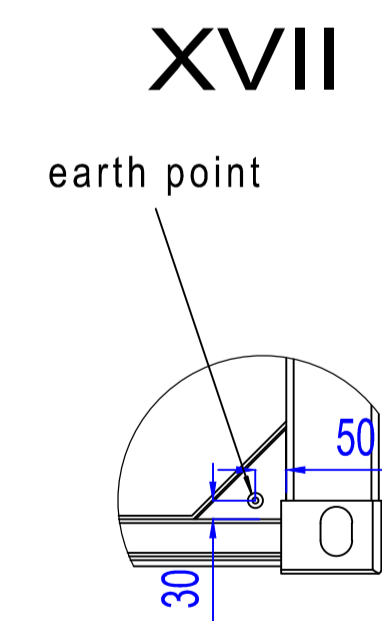
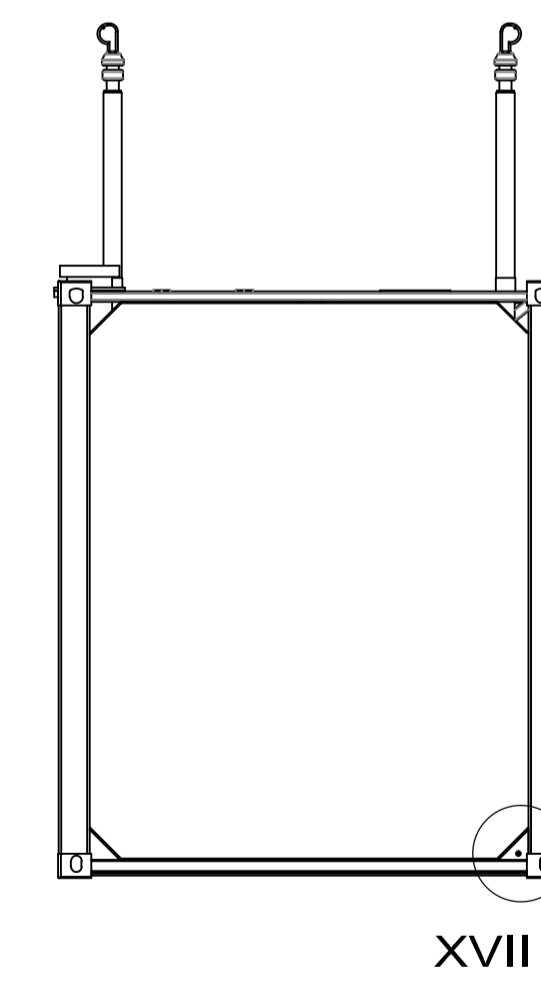
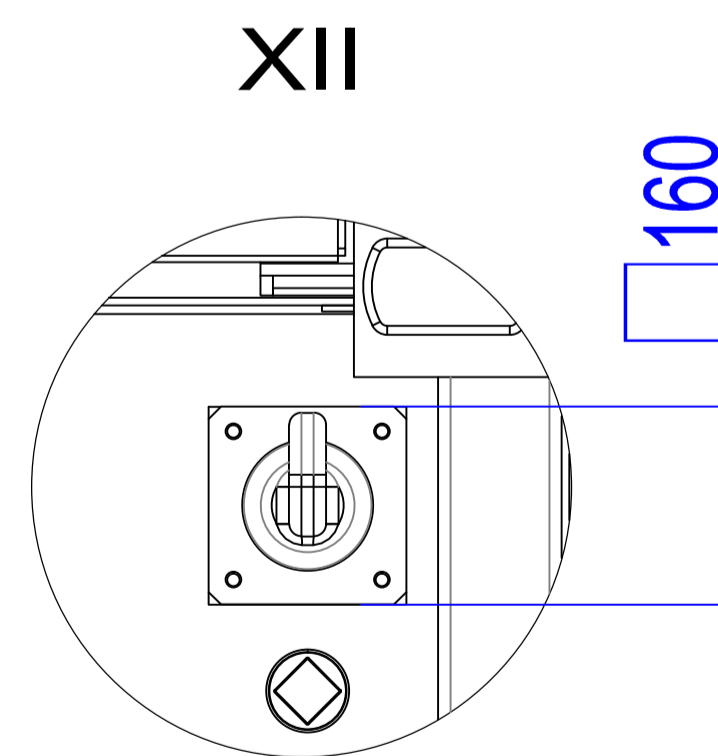
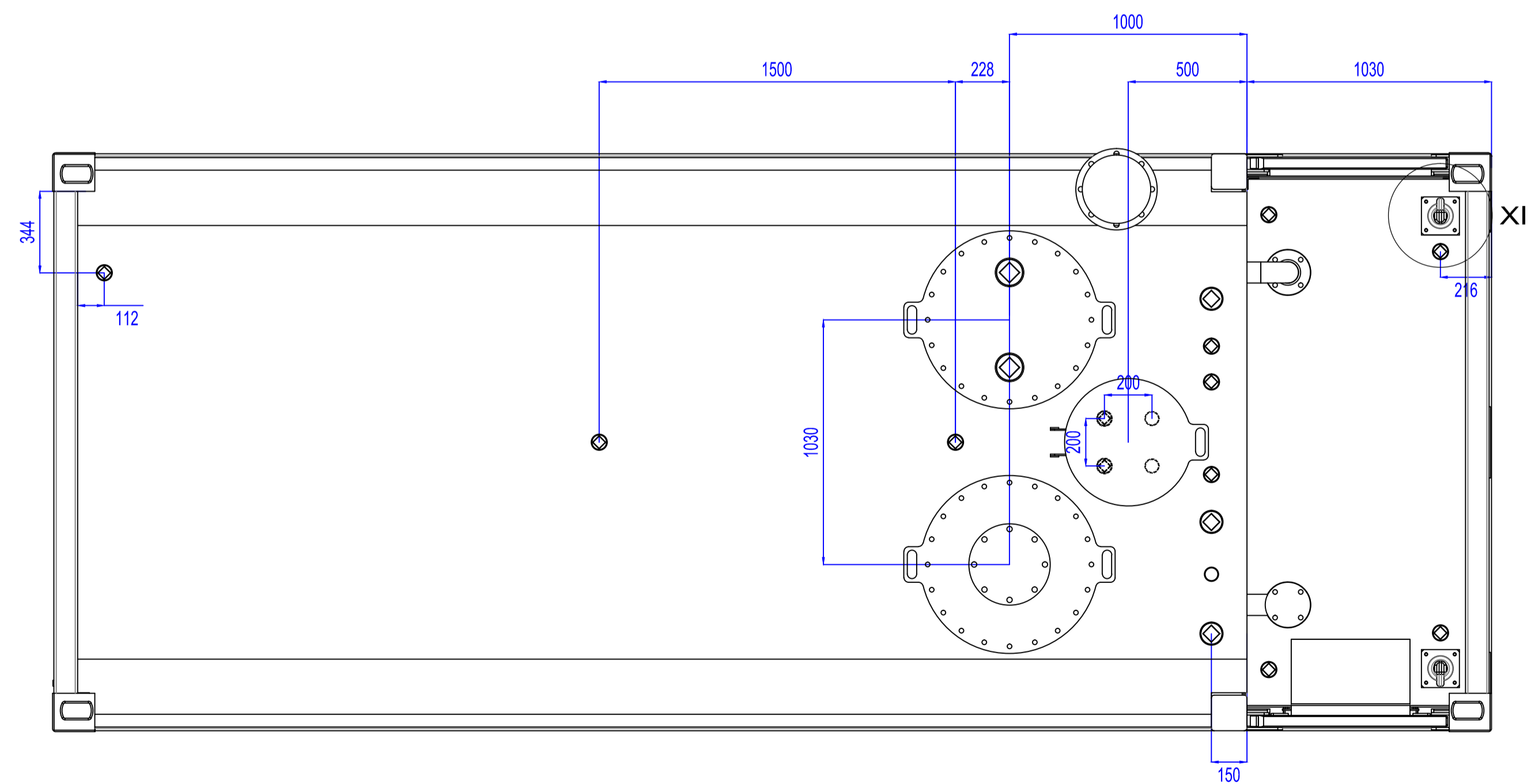
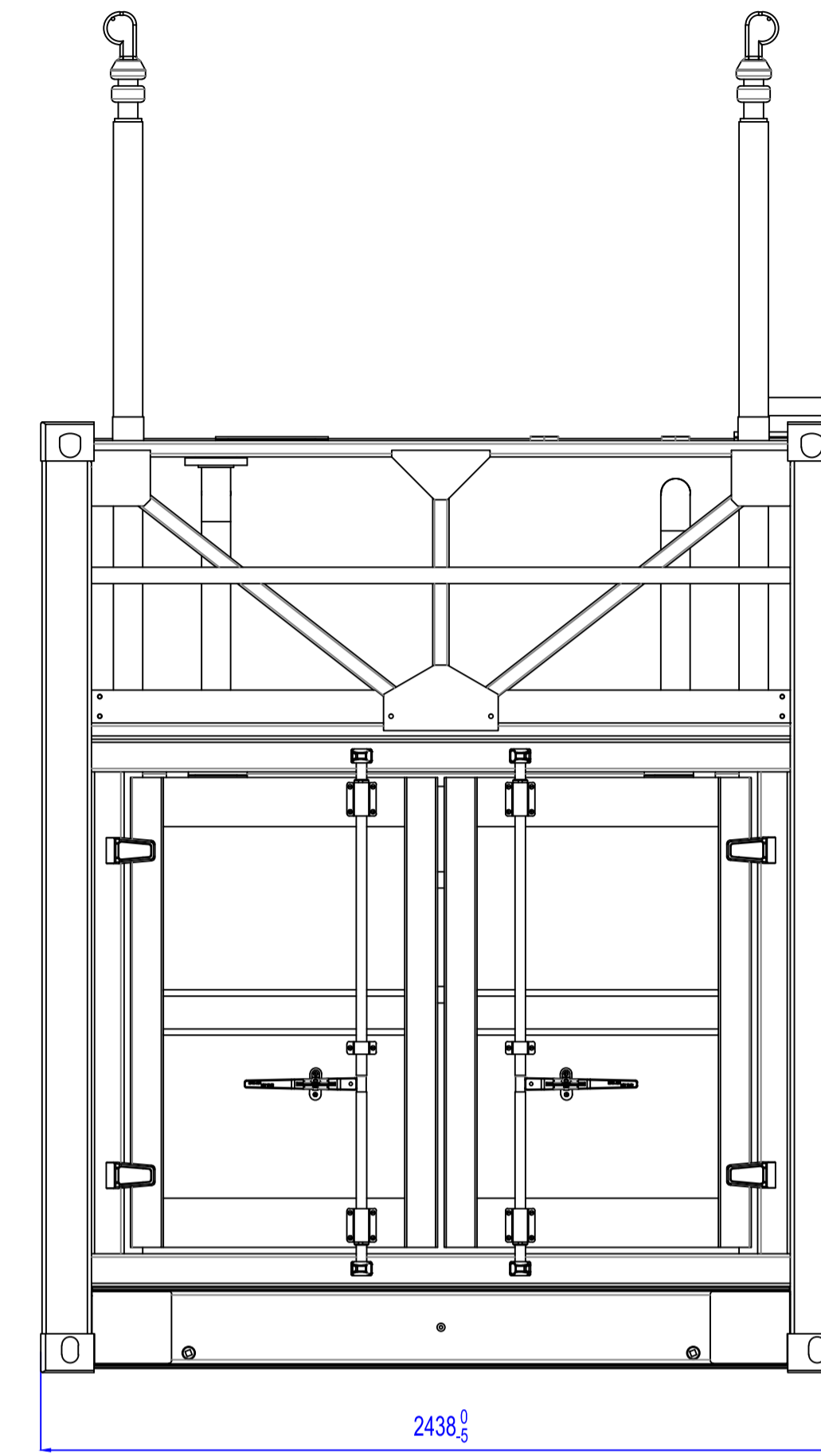
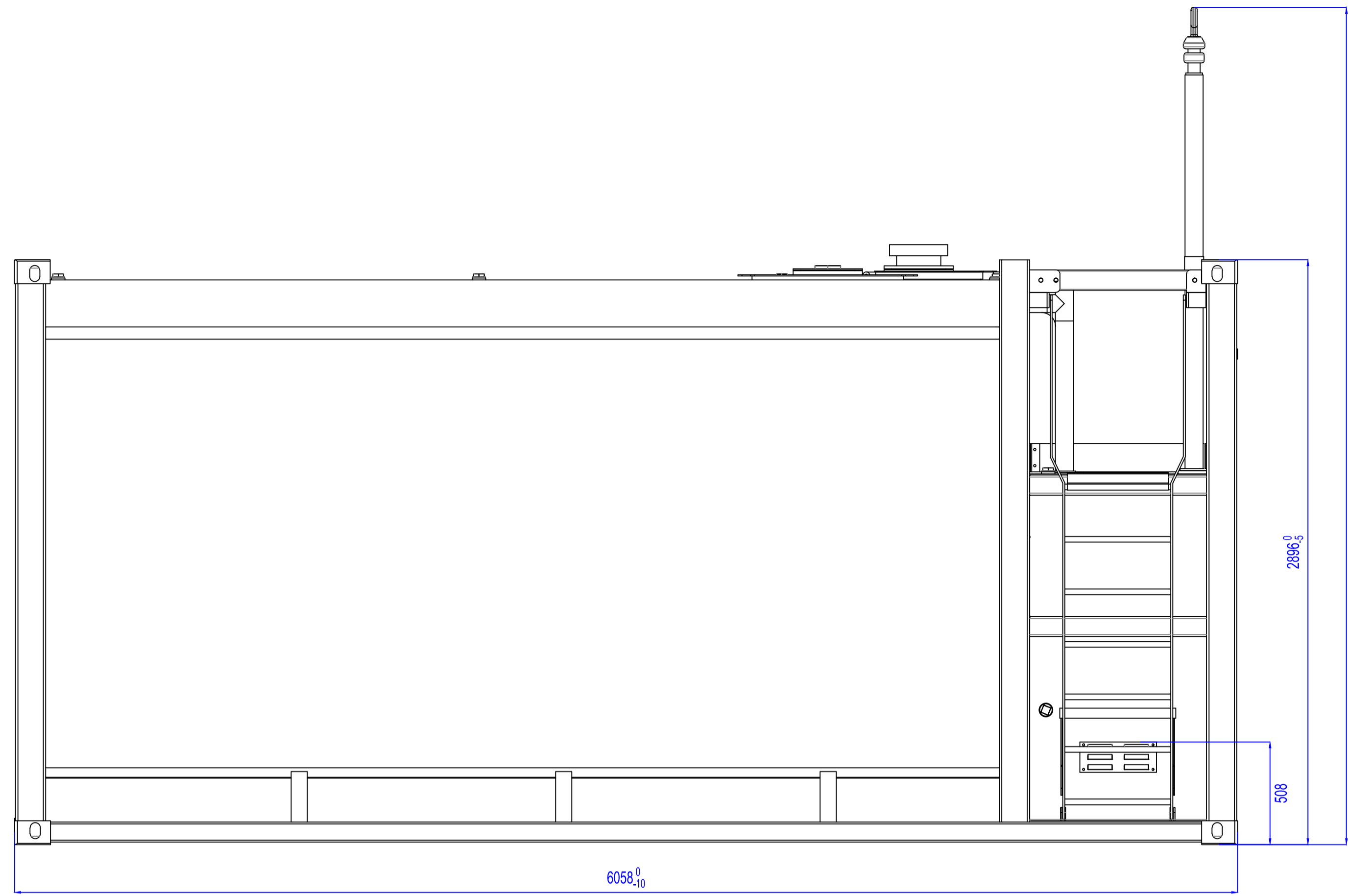

						Project :		
						Part Name : BT-30 LAYOUT		
NO. Changes		SIGN	DATE	Material		Part No :		
Design	File	2024/9/12	Number	Weight		6600 KG		
CHK' D			Scale	Revision		01 SHEET 2 TOTAL SHEET 3		
CHK' D								
APPV' D								

1

2

3

4

5

6

A

B

C

D

E

F

G

H

Autodesk

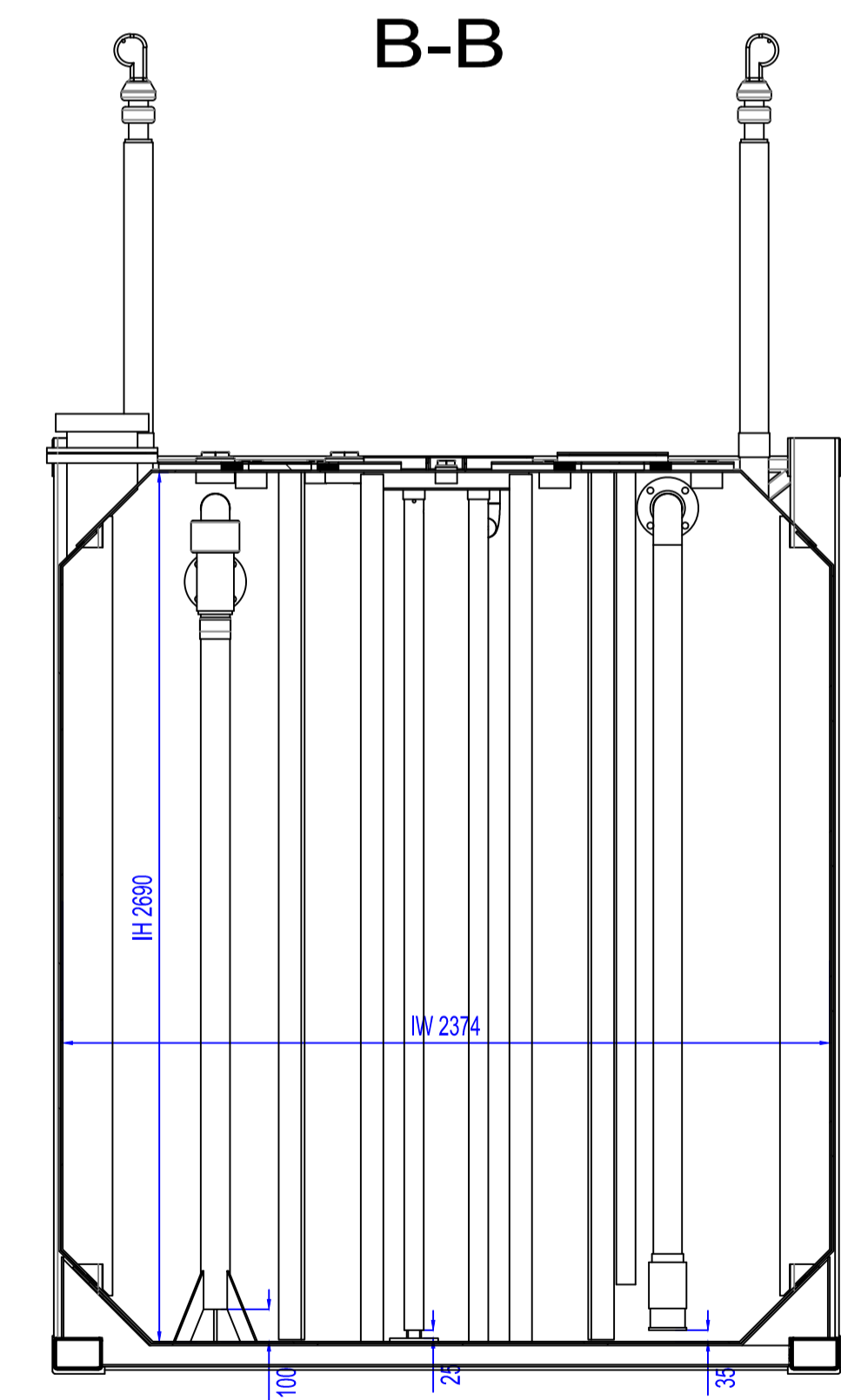
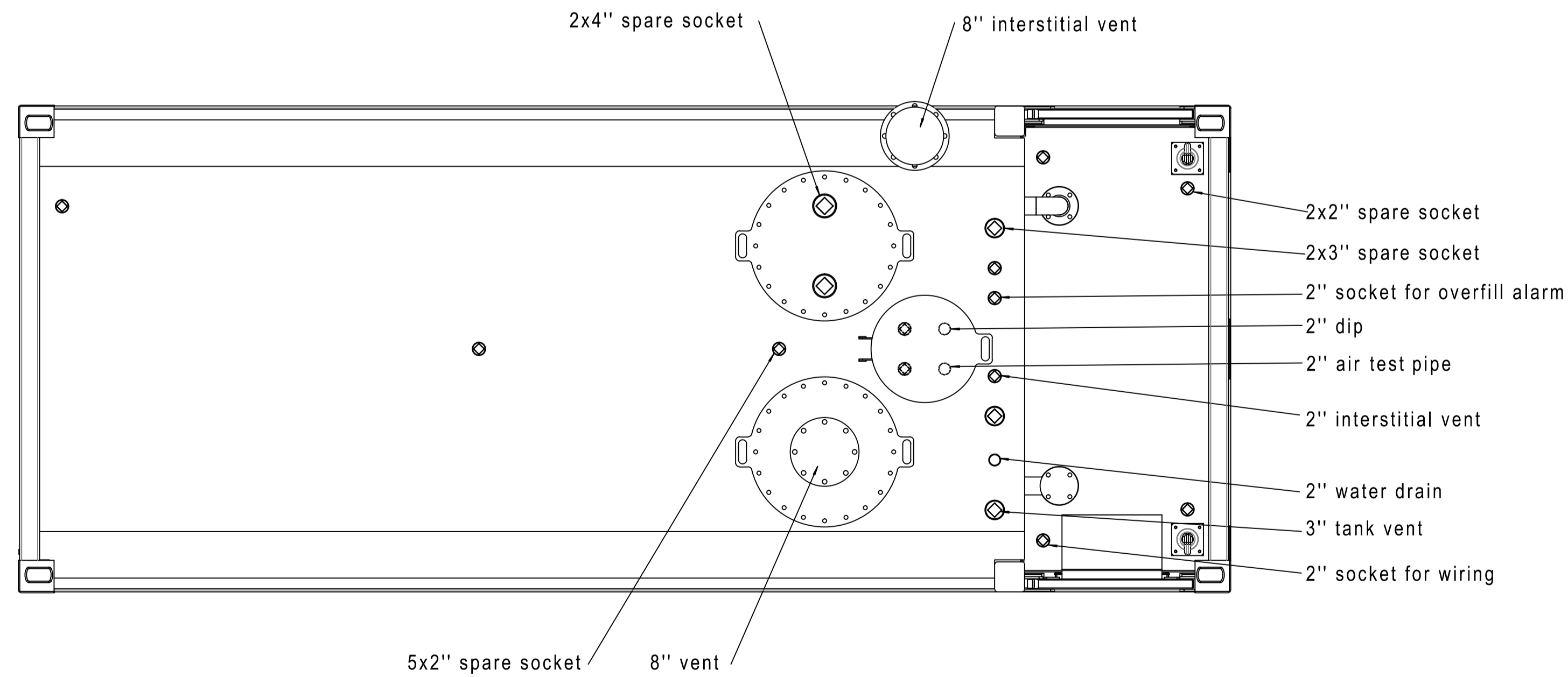
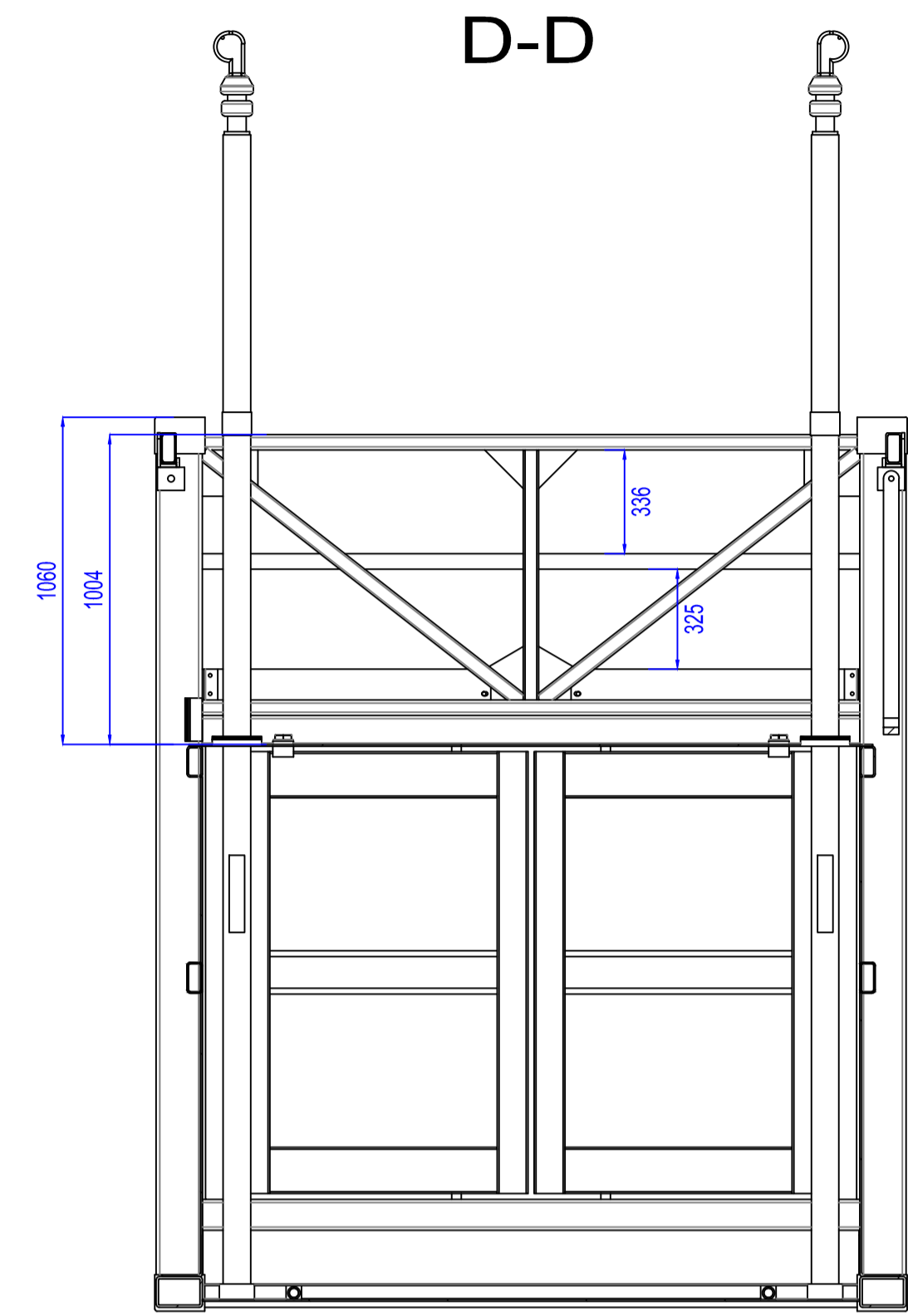
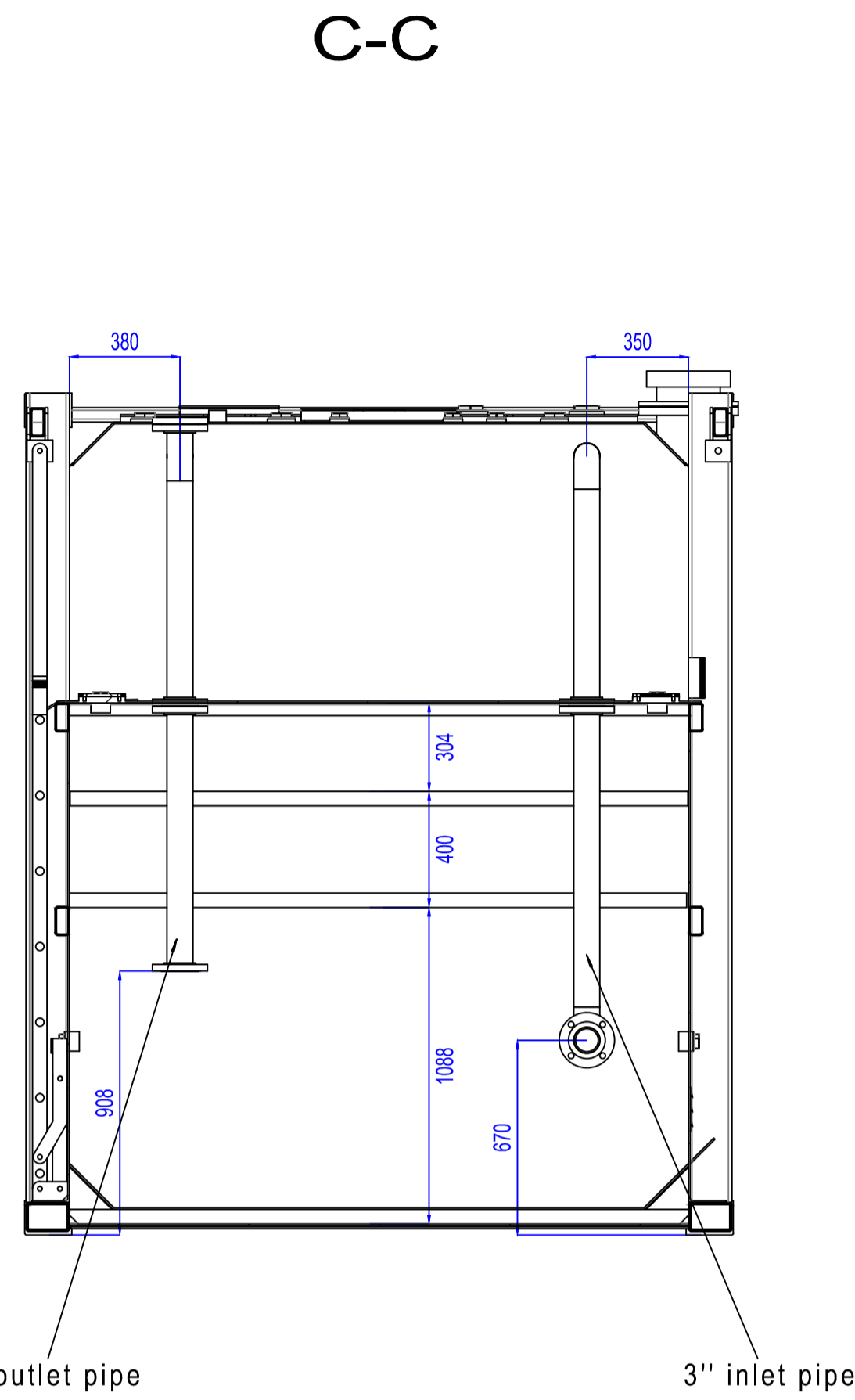
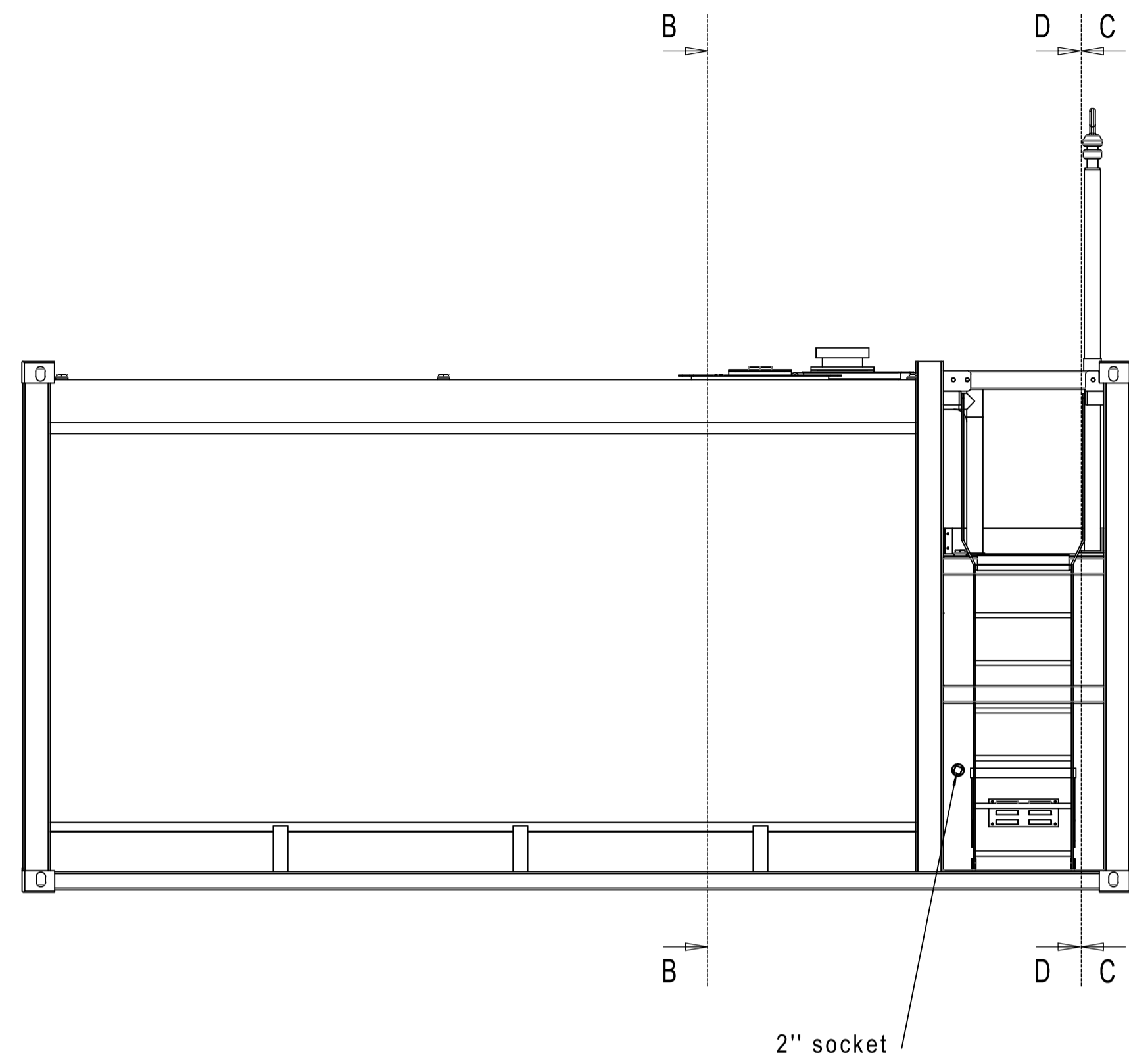

				Project :	
				Part Name : BT-30 LAYOUT	
				Part No :	
				Revision 01 SHEET 3 TOTAL SHEET 3	
				Weight 6600 KG	
				Material	
				Scale	
				Date	
				SIGN	
				Number	
				File	
				2024/9/12	
				NO. Changes	
				CHK' D	
				CHK' D	
				APPV' D	

1

2

3

4

5

6